

# Sump Alarm

## The Premier Heavy Duty Float Switch



The SludgeBoss® heavy duty float switch for use with sewage, suspended solids and viscous liquids

The Sludge Boss is the float switch for extra nasty locations where there is sewage and suspended solids. This heavy duty float switch has an integrated concrete counterweight ensuring its orientation even if held below floating materials.

- No need to enter the tank. SludgeBoss® is self-orienting. Hang it in place and the installation is complete.
- Available in both 6 Meter (20 Foot) and 10 Meter (33 Foot) lengths.
- Rated at 13 Amps or 1/2 HP
- 5 Year Field Failure Warranty
- Temperature ratings from -20F to 140F, and rated to IP68, with CE & IEC approvals

### Features Include:

- Directly Controls pumps up to 1/2 HP at 120 Volts
- Environmental friendly (Mercury Free)
- Suitable for use in septic, sump, and potable water applications
- Built with a Honeywell Micro switch

*Kit comes complete with everything shown.*



INDUSTRY LEADING  
5 YEAR WARRANTY

SumpAlarm.com

## PRODUCT DESCRIPTION

This float switch is rated to directly control motors of up to ½ Horsepower (or 13 Amps) at 120 or 220 Volts AC for non-continuous pump operations. Please feel free to contact us for other applications.

For higher horsepower motors, a contactor or relay will be required.

This float switch is **made for EMPTYING OPERATIONS / DETECTING HIGH LEVEL**. If your application is for FILLING, this product will not work for you. Contact us and we will help you find a suitable product.

The molded piggyback plug is unique to grounded 120 Volt applications. Your pump needs a ground and should be plugged into a GFCI receptacle. Your pump will plug directly into the Piggyback Float Switch, and the float switch will turn the pump on and off automatically.

## PRODUCT INFORMATION

Product Dimensions:	7 x 4.5 x 4.5 inches
Item Weight:	2.95 lbs
Shipping Weight:	2.95 lbs.
Style:	Piggyback - Pump to Empty
Cord Length:	16 and 20 Ft
Part Numbers:	SA-3120-5 & SA-3120-6
Customer Reviews:	4.5 out of 5 stars

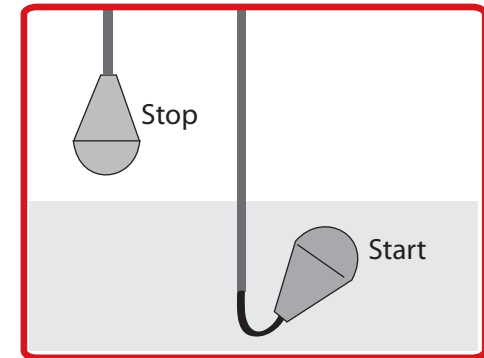
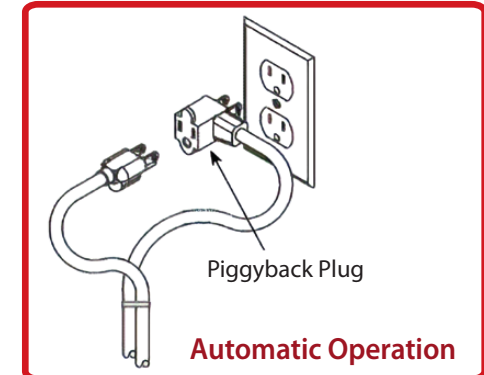
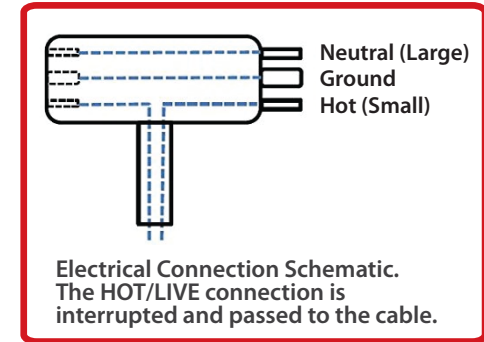

THE PREMIERE  
HEAVY DUTY  
FLOAT SWITCH

Simply the **Best** heavy duty float switch on the market. Period.